



## FITTING INSTRUCTIONS FOR MS2 SPLINE MODIFICATION KIT

Remove the old female coupling from the flywheel along with the bolts and discard,

Replace bolts with new polyurethane headed replacements and washers supplied, (New female coupling is NOT bolted to flywheel in any way)

It is important that when installed, the new drive coupling is free to float approximately 0.5-1.0 mm on the hexagonal shaft, to ensure this is the case use the following procedure –

- ❖ Place 3 shims on the hex shaft and fit the new damper coupling.
- ❖ Measure distance **A** between the face of the flywheel housing and the face of one of the newly fitted washers
- ❖ Measure the distance **B** between the gearbox mating face and the front face of the new coupling (ensuring the coupling and shim are pushed back against the shoulder)
- ❖ After subtracting **B from A** calculate the correct amount of shims required from the table below.
- ❖ **NOTE, all shims are 1.0mm thick**

DISTANCE MEASUREMENTS	Amount of shim required
A minus B = 0mm to – 1mm	2mm
A minus B = 0mm to + 1mm	3mm
A minus B = +2mm to + 1mm	4mm
A minus B = +3mm to + 2mm	5mm
A minus B = +4mm to + 3mm	6mm

### The correct torque for the bolts is 65N

On final assembly, the coupling should be mounted on the heads of the drive bolts and gearbox offered up to it.

UNIT 2 WEST END INDUSTRIAL ESTATE, PENRYN, CORNWALL,.TR10 8RT

TEL 01326 290501

<http://www.versatilemarine.co.uk/> email [info@versatilemarine.co.uk](mailto:info@versatilemarine.co.uk)



**NOTE, VERSATILE MARINE RECOMMEND THAT THIS INSTALLATION IS INSPECTED FOR WEAR AT LEAST EVERY 2 YEARS**

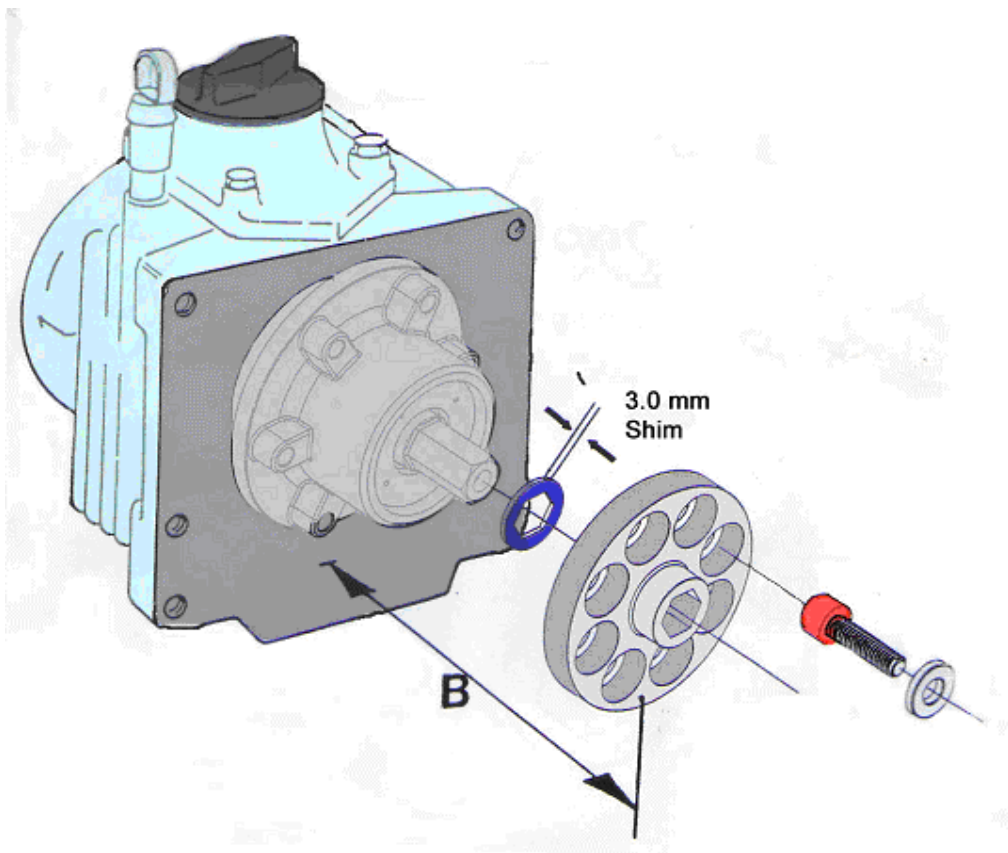

UNIT 2 WEST END INDUSTRIAL ESTATE, PENRYN, CORNWALL, TR10 8RT

TEL 01326 290501

<http://www.versatilemarine.co.uk/> email [info@versatilemarine.co.uk](mailto:info@versatilemarine.co.uk)

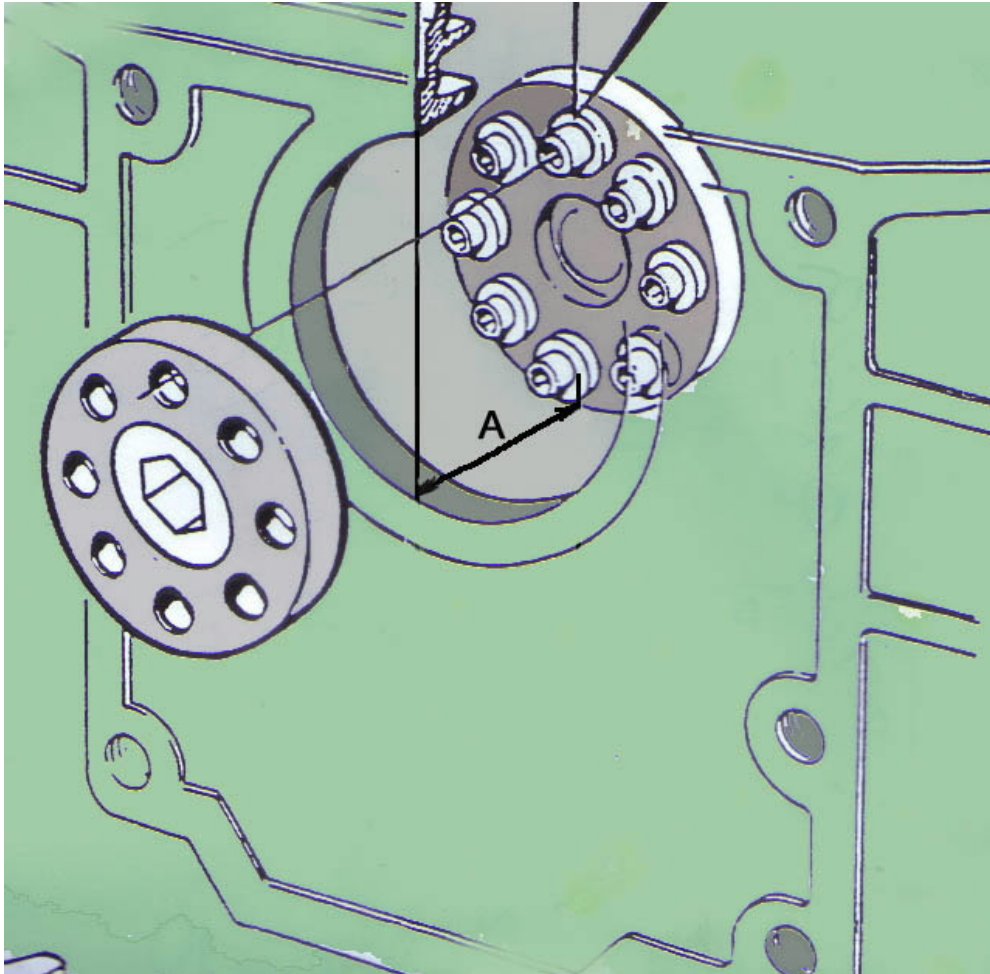

UNIT 2 WEST END INDUSTRIAL ESTATE, PENRYN, CORNWALL, TR10 8RT

TEL 01326 290501

<http://www.versatilemarine.co.uk/> email [info@versatilemarine.co.uk](mailto:info@versatilemarine.co.uk)